

# HYDRAULIC MOTORS OP



## OIL FLOW IN DRAIN LINE

Pressure drop (bar)	Viscosity (mm <sup>2</sup> /s)	Oil flow in drain line (l/min)
100	20	2,5
	35	1,8
140	20	3,5
	35	2,8



## GENERAL

Displacement, (cm <sup>3</sup> /rev)	25 ÷ 623,6
Max. Speed, (RPM)	1600 ÷ 95
Max. Torque, (daNm)	3,3 ÷ 50
Max. Output, (kW)	3,3 ÷ 10,5
Max. Pressure Drop, (bar)	140 ÷ 55
Max. Oil Flow, (l/min)	40 ÷ 60
Min. speed, (RPM)	10
Pressure fluid	Mineral based - HLP (DIN 51524) or HM (ISO 6743/4)
Temperature range, (°C)	- 30 ÷ 90
Optimal Viscosity range, (mm <sup>2</sup> /s)	20 ÷ 75
Filtration	ISO code 20/16 (Min. recommended fluid filtration of 25 micron)

## PRESSURE LOSSES

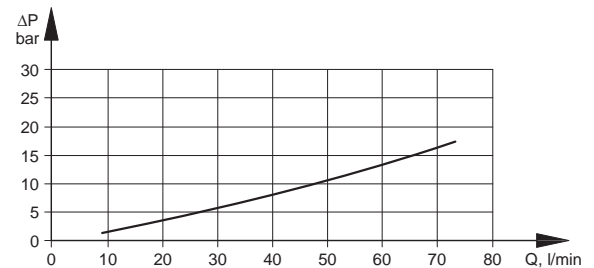

## SPECIFICATION DATA

Type		OP 25	OP 32	OP 40	OP(W) 50	OP 50..B...	OP(W) 80	OP 80..B...	OP(W) 100	OP 100..B...	OP125	OP 125..B...	OP 160	
Displacement [cm <sup>3</sup> /rev.]		25	32.0	40.0	49,5	49,5	79,2	79,2	99	99	123,8	123,8	158,4	
Max. Speed, [RPM]	cont.	1600	1560	1500	1210	1210	755	755	605	605	486	486	378	
	int.	1800	1720	1750	1515	1515	945	945	755	755	605	605	472	
Max. Torque [daNm]	cont.	3.3	4.3	6.2	9.4	9.4	15,1	15,1	19,3	19,3	23,7	23,7	31,3	
	int.	4.7	6.1	8.2	11,9	11,9	19,5	19,5	23,7	23,7	29,8	29,8	37,8	
	peak	6.7	8.6	10.7	14,3	14,3	22,4	22,4	27,5	27,5	36,5	36,5	43,8	
Max. Output [kW]	cont.	4.5	5.8	8.4	10,1	10,1	10,2	10,2	10,5	10,5	10	10	10,1	
	int.	6.1	7.8	11.6	12,2	12,2	12,5	12,5	12,8	12,8	12	12	12,1	
Max. Pressure Drop [bar]	cont.	100	100	120	140	140	140	140	140	140	140	140	140	
	int.	140	140	155	175	175	175	175	175	175	175	175	175	
	peak	225	225	225	225	225	225	225	225	225	225	225	225	
Max. Oil Flow [l/min]	cont.	40	50	60	60	60	60	60	60	60	60	60	60	
	int.	45	55	70	75	75	75	75	75	75	75	75	75	
Max. Inlet Pressure, [bar]	cont.	175	175	175	175	175	175	175	175	175	175	175	175	
	int.	200	200	200	200	200	200	200	200	200	200	200	200	
	peak	225	225	225	225	225	225	225	225	225	225	225	225	
Max. Return Pressure w/o Drain Line or Max. Pressure in Drain Line, [bar]	cont.	0-100	RPM	150	150	150	150	100	150	100	150	100	150	
	cont.	100-300	RPM	75	75	75	75	30	75	30	75	30	75	
	cont.	300-600	RPM	50	50	50	50	15	50	15	50	15	50	
	cont.	>600	RPM	20	20	20	20	-	20	-	20	-	-	
	int.	0-max.	RPM	150	150	150	150	100	150	100	150	100	150	
Max. Return Pressure with Drain Line [bar]	cont.			175	175	175	175	175	175	175	175	175	175	
	int.			200	200	200	200	200	200	200	200	200	200	
	peak			225	225	225	225	225	225	225	225	225	225	
Max. Starting Pressure with Unloaded Shift, [bar]				10	10	10	10	10	10	10	9	9	8	
Min. Starting Torque [daNm]	at max press. drop cont.			3	4	5.4	7,8	7,8	13,2	13,2	16,6	16,6	20,7	
	at max press. drop int.			4.2	5.6	6.9	10	10	16,8	16,8	21	21	26,6	
Min. Speed, [RPM]				20	15	10	10	10	10	10	10	10	10	
Weight avg, [kg]	OP(F)			5.6	5.6	5.7	5.8		5.9		6.1		6.4	
	OP(F)(E)...B...							5,9(6,4)		6(6,5)		6,2(6,7)		6,3(6,8)
	OPQ(N)								5,2		5,3		5,5	
	OP(F)(N)E								6,3		6,4		6,6	
	OPW(N)								5,5		5,6		5,8	
OPQ(N)E								5,7		5,8		6,0		

Intermittent operation: the permissible values may occur for max. 10% of every minute.  
Peak load: the permissible values may occur for max. 1% of every minute.

## SPECIFICATION DATA

Type		OP 160...B...	OP 200 OPW 200	OP 200...B...	OP(W) 250	OP 250...B...	OP(W) 315	OP 315...B...	OP(W) 400	OP 400...B...	OP 500	OP 630
Displacement [cm³/rev.]		158,4	198	198	247,5	247,5	316,8	316,8	396	396	495	623,6
Max. Speed, [RPM]	cont.	378	303	303	242	242	190	190	150	150	120	95
	int.	472	378	378	303	303	236	236	189	189	150	120
Max. Torque [daNm]	cont.	31,3	36,6	36,6	38	47	38	48,6	36	50	39	44
	int.	37,8	45,6	45,6	58,3	58,3	56	56	59	59	57	64
	peak	43,8	55	55	68,5	68,5	85	85	85,4	85,4	78	82
Max. Output [kW]	cont.	10,1	10	10	7,5	9,5	5,7	7,6	4,6	6,2	3,5	3,3
	int.	12,1	12	12	12	12	9	9	7,8	7,8	7,2	5,6
Max. Pressure Drop [bar]	cont.	140	140	140	110	140	90	120	70	95	60	55
	int.	175	175	175	175	175	140	140	115	115	90	80
	peak	225	225	225	225	225	225	225	180	180	130	110
Max. Oil Flow [l/min]	cont.	60	60	60	60	60	60	60	60	60	60	60
	int.	75	75	75	75	75	75	75	75	75	75	75
Max. Inlet Pressure, [bar]	cont.	175	175	175	175	175	175	175	175	175	140	140
	int.	200	200	200	200	200	200	200	200	200	175	175
	peak	225	225	225	225	225	225	225	225	225	225	225
Max. Return Pressure w/o Drain Line or Max. Pressure in Drain Line, [bar]	cont.	0-100	RPM	100	150	100	150	100	150	100	150	150
	cont.	100-300	RPM	30	75	30	75	30	75	30	75	-
	cont.	300-600	RPM	15	50	15	-	-	-	-	-	-
	cont.	>600	RPM	-	-	-	-	-	-	-	-	-
	int.	0-max.	RPM	100	150	100	150	100	150	100	150	150
Max. Return Pressure with Drain Line [bar]	cont.	175	175	175	175	175	175	175	175	175	140	140
	int.	200	200	200	200	200	200	200	200	200	175	175
	peak	225	225	225	225	225	225	225	225	225	225	225
Max. Starting Pressure with Unloaded Shift, [bar]		8	7	7	6	6	5	5	5	5	5	5
Min. Starting Torque [daNm]	at max press. drop cont.	28,2	33,5	33,5	33,6	42,8	34,4	45,8	34,5	46,8	36	41,5
	at max press. drop int.	35,5	42,6	42,6	54,2	54,2	61,9	61,9	60,8	60,8	54	62
Min. Speed, [RPM]		10	10	10	10	10	10	10	10	10	10	10
Weight, avg. [kg]	OP(F)		6,6		6,8		7,1		7,6		8,9	9,5
	OP(F)(E)...B...	6,5(6,9)		6,7(7,2)		6,9(7,4)		7,2(7,7)		7,7(8,2)		
	OPQ(N)		6,0		6,2		6,5		6,8		8,3	9,0
	OP(F)(N)E		7,1		7,3		7,6		8,1		9,3	10
	OPW(N)		6,3		6,5		6,8		7,2			
	OPQ(N)E		6,5		6,7		7,0		7,3		8,8	8,5

Intermittent operation: the permissible values may occur for max. 10% of every minute.

Peak load: the permissible values may occur for max. 1% of every minute.

## SPECIFICATION DATA for OP...LSV

**Low Speed Valve (LSV)** "LSV" Series hydraulic motors have been designed to operate with normal pressure drop and to ensure smooth run at low speed (up to 200 RPM), as the best security for operation is guaranteed at frequency of rotation  $20 \div 50$  RPM. They have an increased starting pressure drop and are not recommended for using at pressure less than 40 bar.

Look at specification data for hydraulic motors standard version. The modification concerns only the following parameters: maximum speed, maximum output, maximum Oil flow and maximum starting pressure.

Type		OP 25	OP 32	OP 40	OP 50	OP 80	OP 100	OP 125	OP 160	OP 200	OP 250	OP 315	OP 400	OP 500	OP 600
Max. Speed, [RPM]	cont.	200	200	200	200	200	200	200	200	200	200	190	150	80	64
	int.	250	250	250	250	250	250	250	250	250	250	236	190	101	80
Max. Output [kW]	cont.	0,7	0,9	1,2	2,0	3	3,8	4,9	6,1	7,0	5,2	4,2	3,4	2,9	2,6
	int.	1,2	1,5	2,0	3,2	5	6,0	7,2	9,5	9,8	9,1	7,2	6,0	5,0	4,2
Max. Oil Flow [l/min]	cont.	9,0	11,0	11	15	22	24	30	34	40	40	40	40	40	40
	int.	13,5	16,5	14	20	29	33	38	46	50	50	50	50	50	50
Max. Starting Pressure with Unloaded Shift, [bar]		25	25	25	20	20	20	20	15	15	15	12	12	10	10

## SPECIFICATION DATA for OP...LL

**Low Leakage (LL)** "LL" Series hydraulic motors have been designed to operate at the whole standard range of working conditions (pressure drop and frequency of rotation), but with considerable decreased volumetric losses in the drainage ports. Their main purpose is to operate as series-connected motors in hydraulic systems. For this version is permissible decreasing of the maximal torque with up to 5% (at middle speed) and up to 10% (at high speed) in comparison to the standard versions of motors.

Look at specification data for hydraulic motors series OP standard version. The modification concerns only the parameters: maximum torque, maximum output, minimum starting torque.

Type		OP 25	OP 32	OP 40	OP 50	OP 80	OP 100	OP 125	OP 160	OP 200	OP 250	OP 315	OP 400	OP 500	OP 600
<b>Max. Torque [daNm]</b>	cont.	3,1	4,1	5,8	9,0	14,4	18,4	22,5	29,8	34,8	44,6	46,2	47,5	38	42,8
	int.	4,3	5,8	7,8	11,3	18,5	22,5	28,3	36,0	43,3	55,4	53,2	56,0	55	62,0
<b>Max. Output [kW]</b>	cont.	4,3	5,6	8,2	10	10,1	10,4	9,9	10	9,9	9,4	7,5	6,1	3,4	3,2
	int.	6,0	7,7	11,5	12	12,3	12,6	11,8	12	11,8	11,8	8,9	7,7	7,1	5,5
<b>Max. Pressure Drop [bar]</b>	cont.	100	100	120	140	140	140	140	140	140	140	120	95	60	55
	int.	140	140	155	175	175	175	175	175	175	175	140	115	90	80
<b>Min. Starting Torque [daNm]</b>	cont.	4,5	5,7	6,8	7,4	12,5	15,8	19,6	26,8	31,8	40,7	43,5	44,5	46	50
	int.	6,0	7,0	8,0	9,5	16,0	20,0	25,2	33,7	40,5	51,5	58,8	57,8	52	60

## SPECIFICATION DATA for OP...FR

**Free Running** version "FR": These are the hydraulic motors with reduced mechanical losses, for which at disengaged condition (unconnected with driving mechanism) the rotation of the shaft could be realized by means of small torque.

This advantage is especially useful at operating with high frequencies of rotation (over 300 min<sup>-1</sup>) and low pressure drop, which is inbred for types with displacements of up to 200 cm<sup>3</sup>. It is normal for these for the different condition of operation to have high torque, as well as high volume losses: the values of the volumetric efficiency are lower (up to 5% for middle and up to 10% for high values of the pressure drop), than those of the normal versions. That's why the recommended operating for "FR" version is for applications with pressure drop up to 100 bar.

Additional advantages of "FR" version are prolonging of the life of the hydraulic motors at high frequencies of rotation, as well as the possibility to use them in systems with big variation of the loading.

Look at specification data for hydraulic motors series OP standard version. Only the parameter Starting Pressure is modified.

Type	OP 25	OP 32	OP 40	OP 50	OP 80	OP 100	OP 125	OP 160	OP 200
<b>Max. Starting Pressure with Unloaded Shaft, [bar]</b>	8	8	8	8	8	8	7,5	6,5	5,5

## FUNCTION DIAGRAMS

**OP 25**

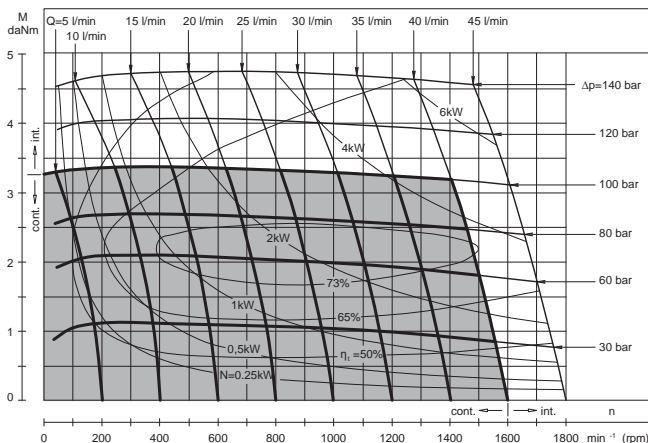

**OP 32**

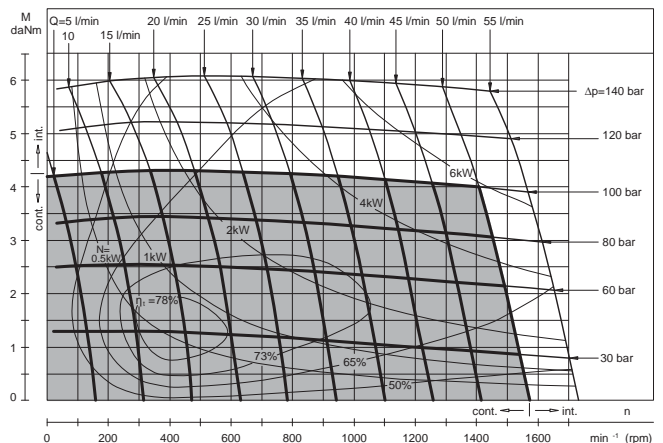

The function diagrams data was collected at back pressure 5±10 bar and oil with viscosity of 32 mm<sup>2</sup>/s at 50° C.

# FUNCTION DIAGRAMS

**OP 40**

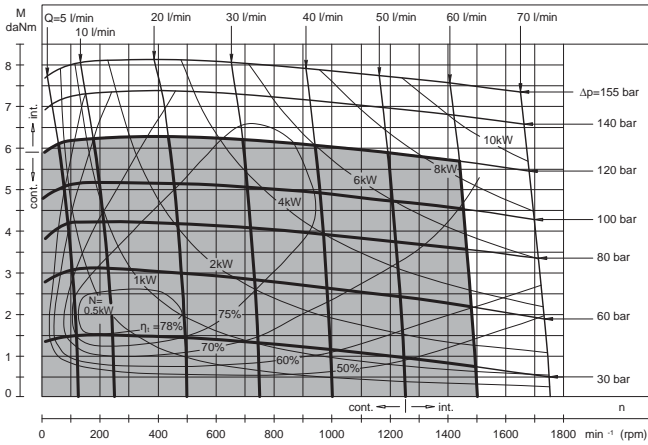

**OP 50**

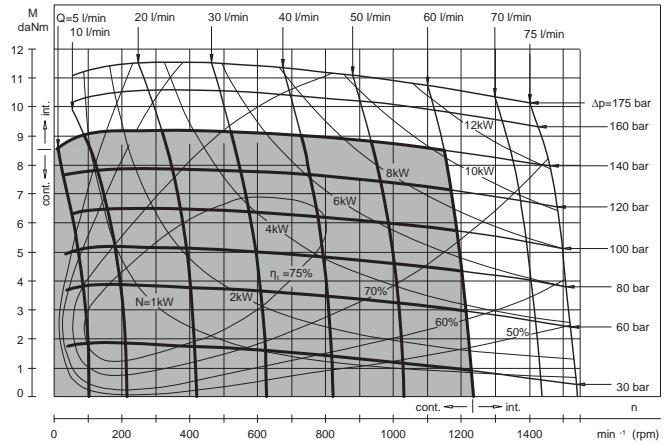

**OP 80**

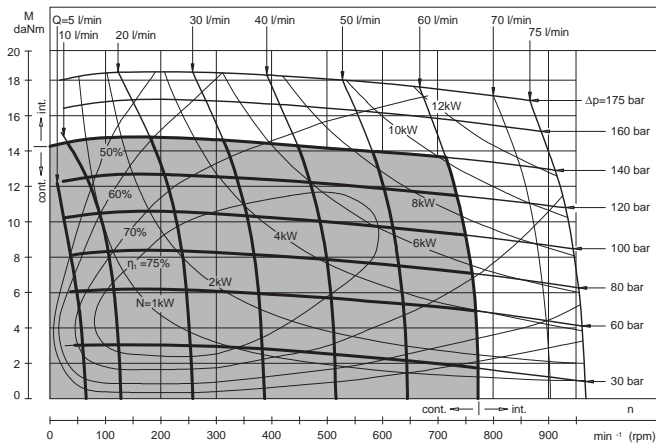

**OP 100**

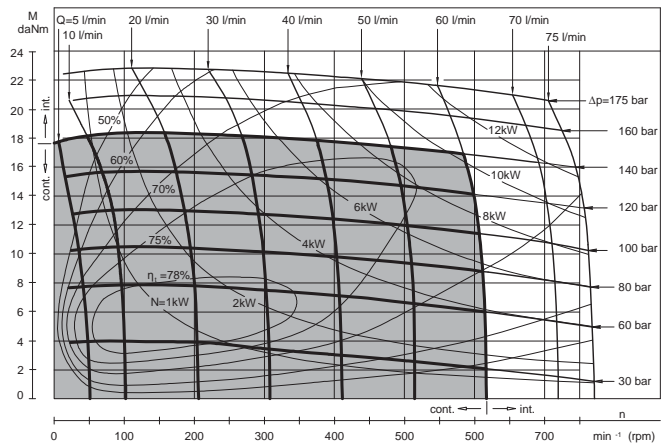

**OP 125**

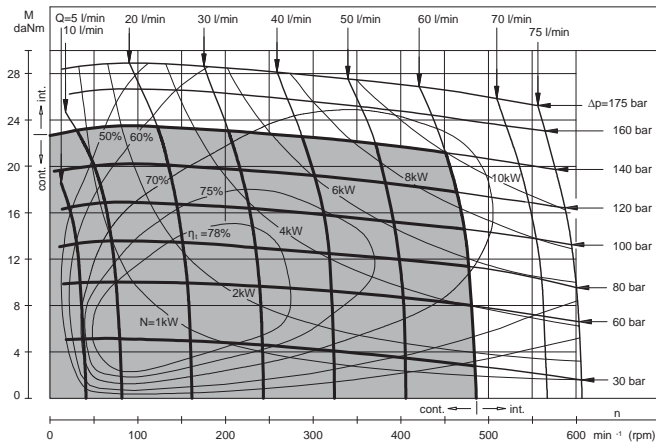

**OP 160**

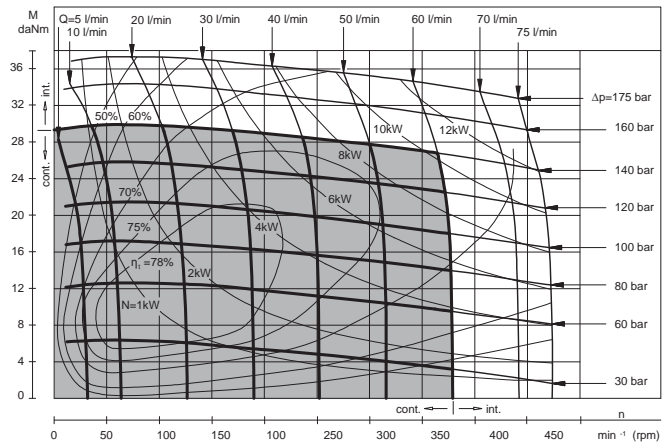

The function diagrams data was collected at back pressure 5÷10 bar and oil with viscosity of 32 mm<sup>2</sup>/s at 50° C.

# FUNCTION DIAGRAMS

**OP 200**

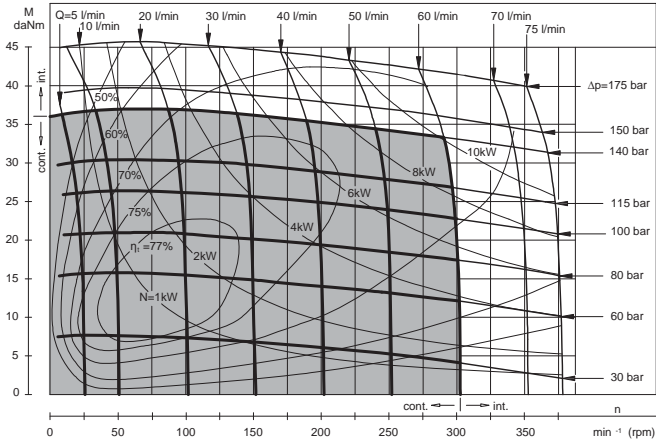

**OP 250**

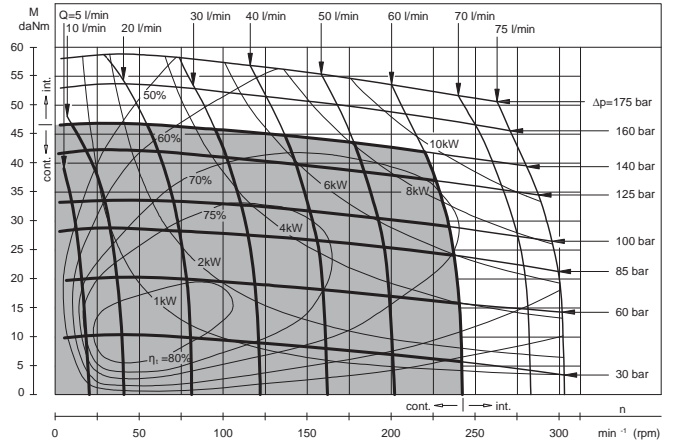

**OP 315**

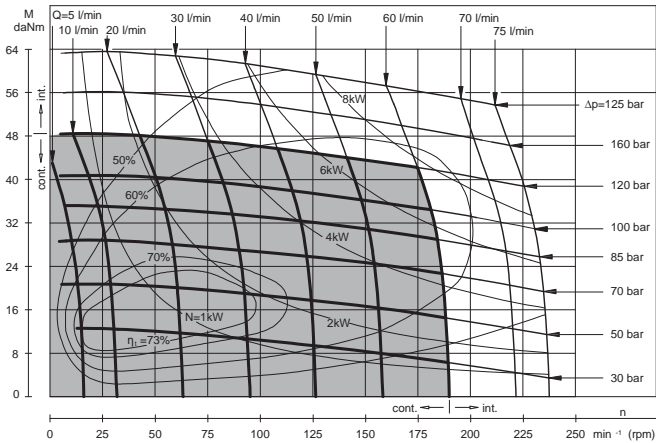

**OP 400**

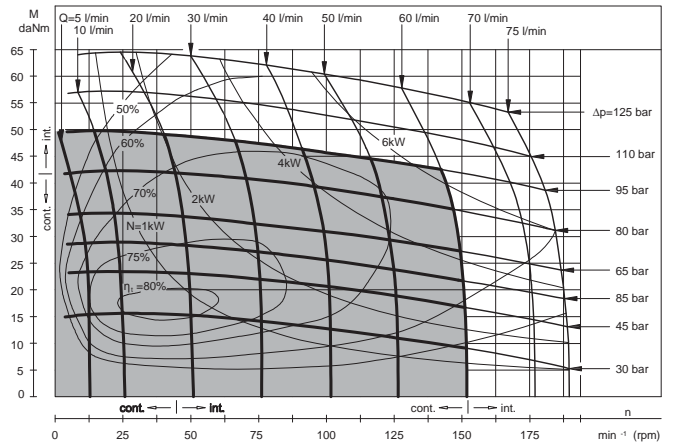

**OP 500**

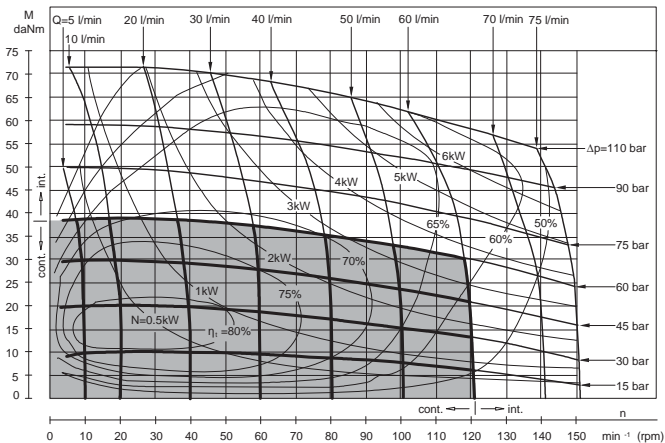

**OP 630**

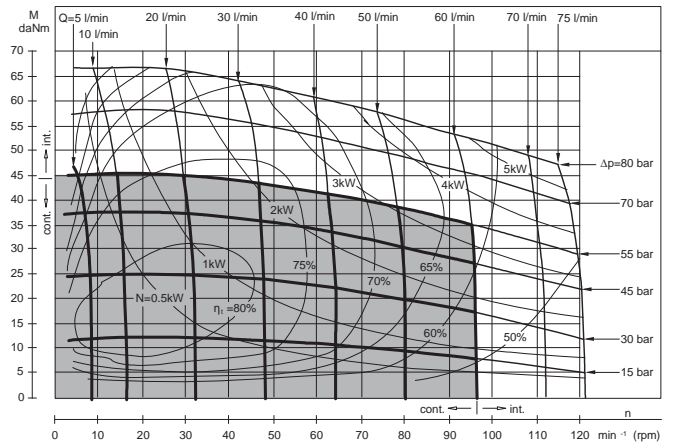

The function diagrams data was collected at back pressure 5÷10 bar and oil with viscosity of 32 mm<sup>2</sup>/s at 50° C.

## DIMENSIONS AND MOUNTING DATA

### PORTING

Side Ports

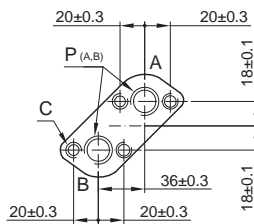

### E Rear Ports

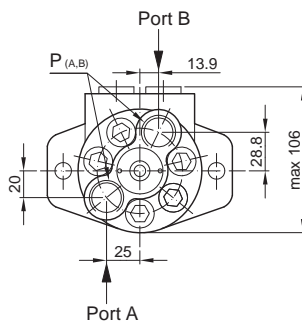

- C : 4xM8 - 13mm depth
- P<sub>(A,B)</sub> : 2xG1/2 or 2xM22x1,5 - 15 mm depth
- T : G1/4 or M14x1,5 - 12 mm depth (plugged)

#### Standard Rotation

Viewed from Shaft End  
 Port A Pressurized - CW  
 Port B Pressurized - CCW

#### Reverse Rotation

Viewed from Shaft End  
 Port A Pressurized - CCW  
 Port B Pressurized - CW

### MOUNTING

Oval Mount (2 Holes)

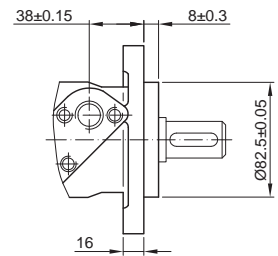
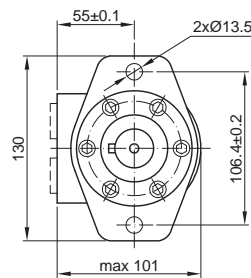

F Oval Mount (4 Holes)

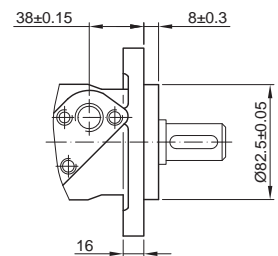
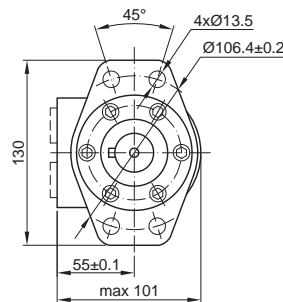

Q Square Mount (4 Bolts)

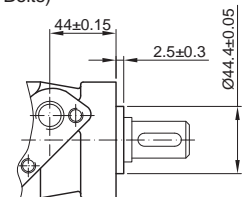
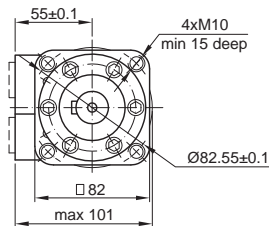

Type	L , mm	Type	L , mm	Type	L , mm	Type	L , mm	L1 , mm
OP(F) 25	133,2	OPQ 25	139,4	OP(F)E 25	151,2	OPQE 25	157,4	4,6
OP(F) 32	137	OPQ 32	143	OP(F)E 32	155	OPQE 32	161	7
OP(F) 40	137	OPQ 40	143	OP(F)E 40	155	OPQE 40	161	7
OP(F) 50	137	OPQ 50	143	OP(F)E 50	155	OPQE 50	161	7
OP(F) 80	140,5	OPQ 80	146,5	OP(F)E 80	160,5	OPQE 80	167	10,5
OP(F) 100	143	OPQ 100	149	OP(F)E 100	163	OPQE 100	169,5	13
OP(F) 125	146	OPQ 125	152	OP(F)E 125	166	OPQE 125	172,5	16
OP(F) 160	151	OPQ 160	157	OP(F)E 160	171	OPQE 160	177,5	21
OP(F) 200	157	OPQ 200	163	OP(F)E 200	177	OPQE 200	183,5	26
OP(F) 250	162	OPQ 250	168	OP(F)E 250	182	OPQE 250	188,5	32
OP(F) 315	172	OPQ 315	178	OP(F)E 315	192	OPQE 315	198,5	42
OP(F) 400	182	OPQ 400	188	OP(F)E 400	202	OPQE 400	208,5	52
OP(F) 500	193	OPQ 500	199	OP(F)E 500	213	OPQE 500	219	66,6
OP(F) 630	210,5	OPQ 630	216,5	OP(F)E 630	230,5	OPQE 630	236,5	84

## DIMENSIONS AND MOUNTING DATA

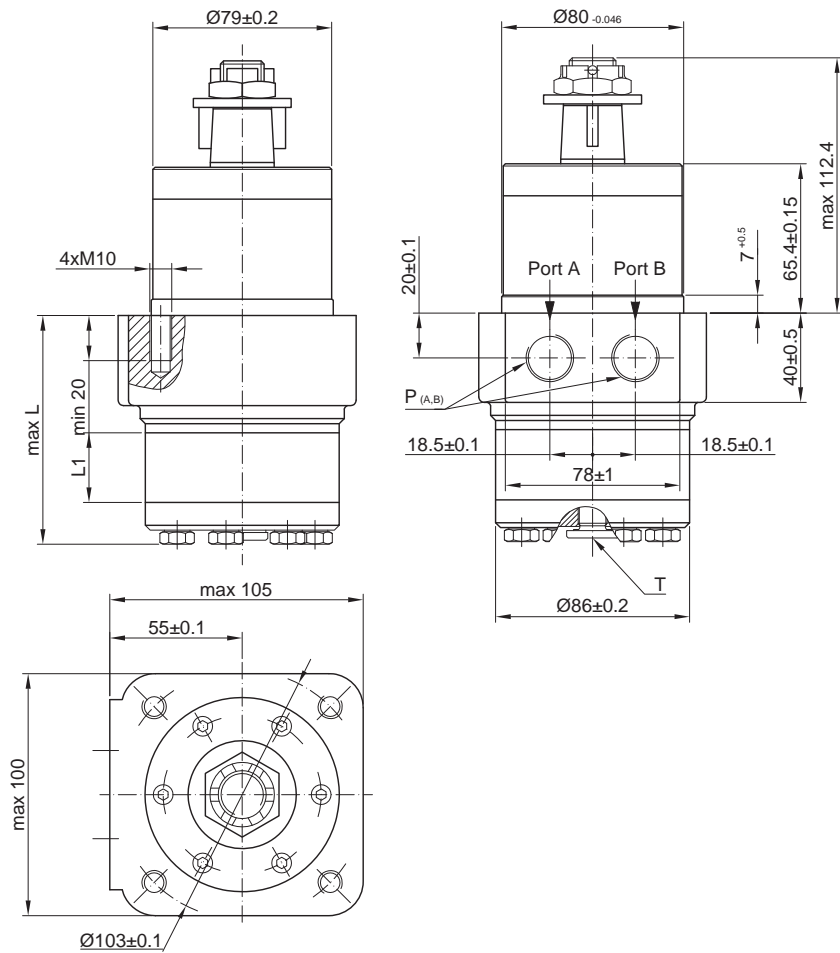

Type	L, mm	L1, mm
OPW(N) 32	81	7
OPW(N) 40	81	7
OPW(N) 50	81	7
OPW(N) 80	84,5	10,5
OPW(N) 100	87	13
OPW(N) 125	90	16
OPW(N) 160	95	21
OPW(N) 200	100	26
OPW(N) 250	106	32
OPW(N) 315	116	42
OPW(N) 400	126	52

### Standard Rotation

Viewed from Shaft End  
 Port A Pressurized - **CW**  
 Port B Pressurized - **CCW**

### Reverse Rotation

Viewed from Shaft End  
 Port A Pressurized - **CCW**  
 Port B Pressurized - **CW**

$P_{(A,B)}$  : 2xG1/2 or 2xM22x1,5 - 15 mm depth

$T$  : G1/4 or M14x1,5 -12 mm depth (plugged)

## PERMISSIBLE SHAFT LOADS

### OPWN

The curves apply to a B10 bearing life of 2000 hours.

- 1: Max. radial shaft load
- 2:  $n = 50 \text{ min}^{-1}$
- 3:  $n = 200 \text{ min}^{-1}$
- 4:  $n = 800 \text{ min}^{-1}$

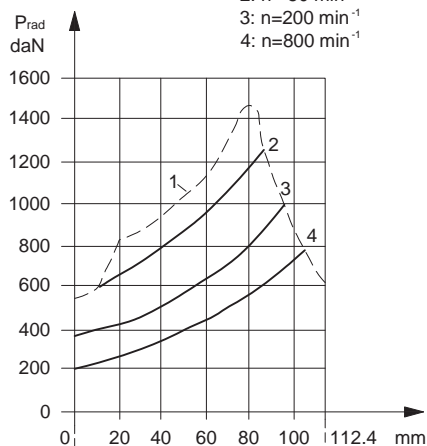

$P_{a_{max}} = 150 \text{ daN}$   
 $P_{a_{max}} = 200 \text{ daN}$

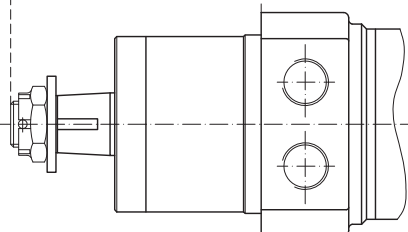

### OPW

- 1: Max. radial shaft load
- 2:  $n = 300 \text{ min}^{-1}$
- 3:  $n = 500 \text{ min}^{-1}$
- 4:  $n = 800 \text{ min}^{-1}$

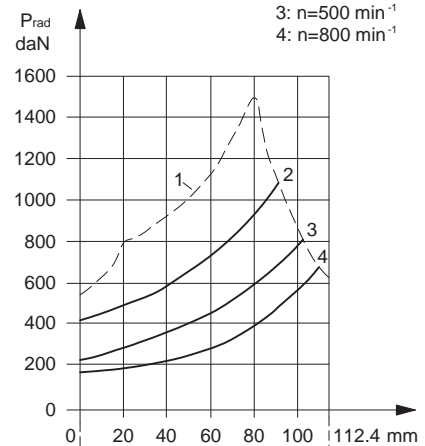

$P_{a_{max}} = 150 \text{ daN}$   
 $P_{a_{max}} = 200 \text{ daN}$

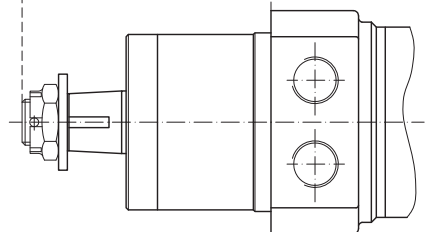

## SHAFT EXTENSIONS FOR OP AND OR MOTORS

**C** Ø25 straight, Parallel key A8x7x32 DIN 6885  
Max. Torque 44 daNm

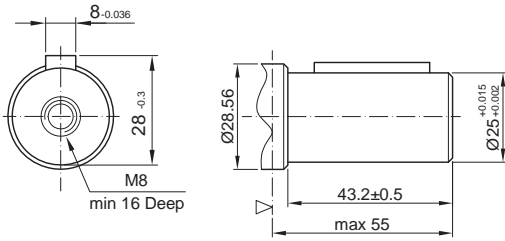

**CB** Ø32 Straight, Paralle key A10x8x45 DIN 6885  
Max. Torque 77 daNm

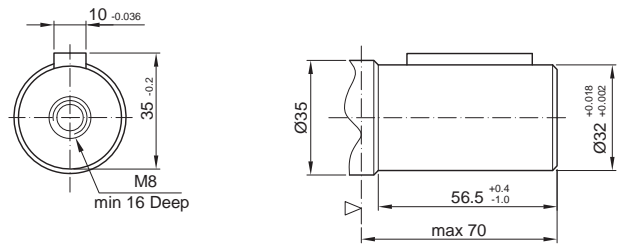

**CO** Ø1" straight, Parallel key 1/4"x1/4"x1 1/4" BS46  
Max. Torque 44 daNm

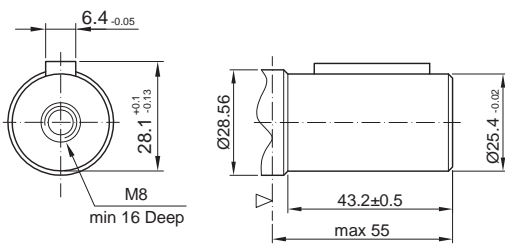

**SB** splined A25x22xH10 DIN 5482  
Max. Torque 44 daNm

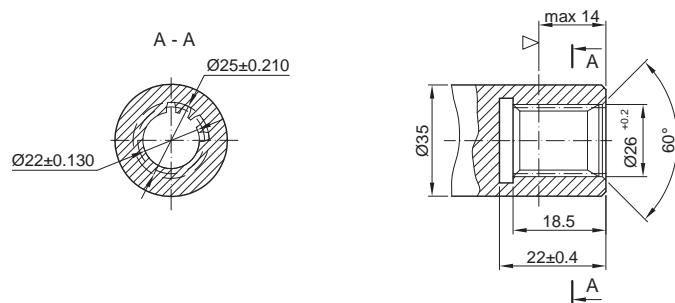

**SH** splined, BS 2059 (SAE 6B)  
Max. Torque 44 daNm

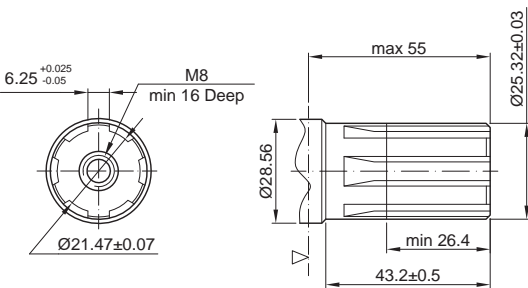

**KB** tapered 1:10, Paralle key B6x6x20 DIN 6885  
Max. Torque 77 daNm

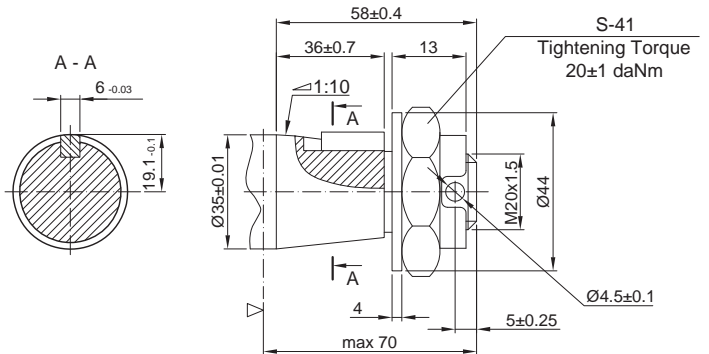

**K** tapered 1:10, Parallel key B5x5x14 DIN 6885  
Max. Torque 40 daNm

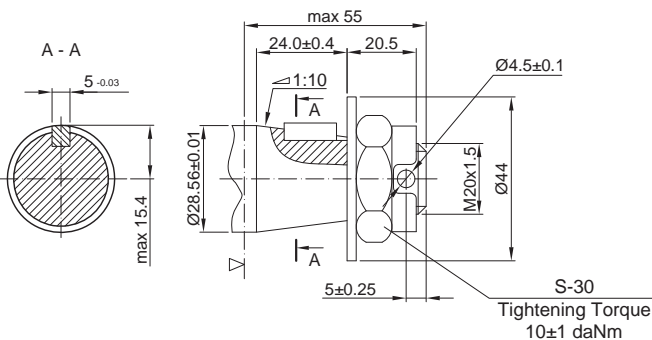

**OB** tapered 1:8 SAEJ 501, Paralle key 5/16"x5/16"x1 1/4" BS46  
Max. Torque 77 daNm

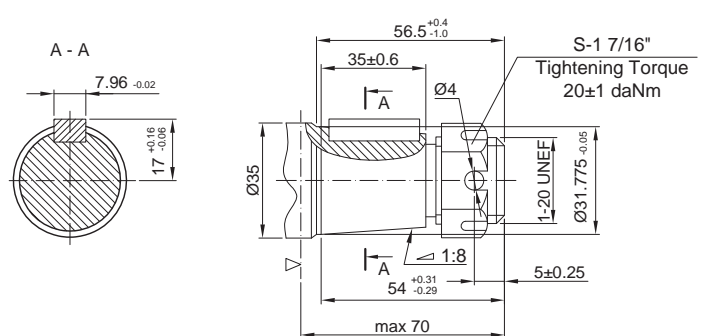

**SA** splined, B25x22h9 DIN 5482  
Max. Torque 40 daNm

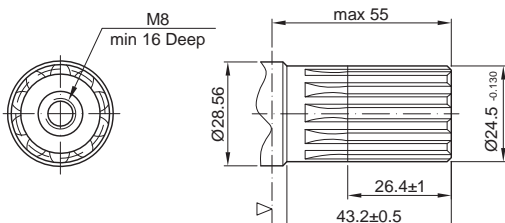

**HB** Ø1 1/4" splined 14T, ANSI B92.1-1976 Norm  
Max. Torque 77 daNm

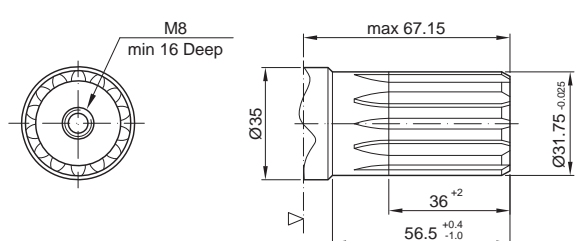

▽ Motor Mounting Surface



## PERMISSIBLE SHAFT LOADS FOR OP MOTORS

The permissible radial shaft load  $P_{rad}$  depends on the speed (RPM) and distance (L) from the point of load to the mounting flange.

Mounting Flange			
Shaft Version	cylindrical - C, CO tapered - K, splined - SH	splined - HB cylindrical - CB	cylindrical - C, CO
Radial Shaft Load $P_{rad}$	$\frac{800}{n} \times \frac{25000}{95+L}$ , daN	$\frac{800}{n} \times \frac{18750}{95+L}$ , daN	$\frac{800}{n} \times \frac{25000}{101+L}$ , daN

$n < 200 \text{ min}^{-1}$ ; max  $P_{rad} = 800 \text{ daN}$   
 $n > 200 \text{ min}^{-1}$ ;  $L < 55 \text{ mm}$

### OPN

The curves apply to a  $B_{10}$  bearing life of 2000 hours.

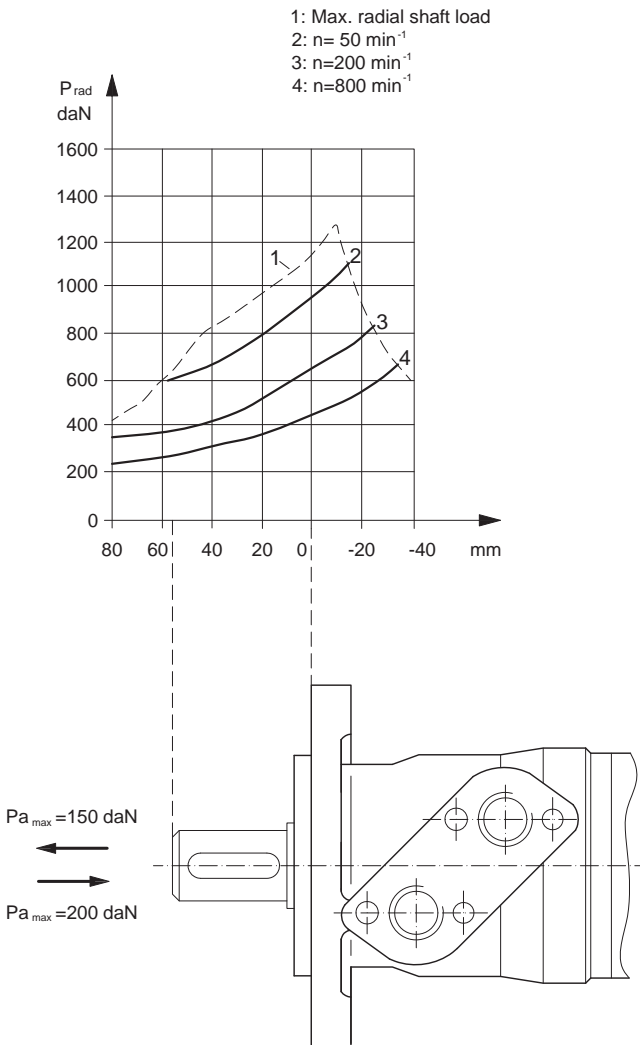

### OP

Radial Shaft Load  $P_{rad}$  for C, CO Shaft Extensions by  $L=30$  (24) mm

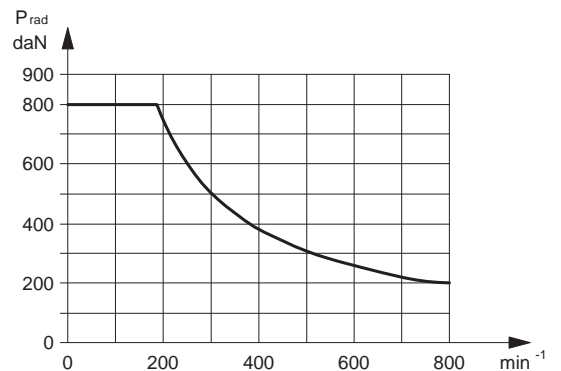
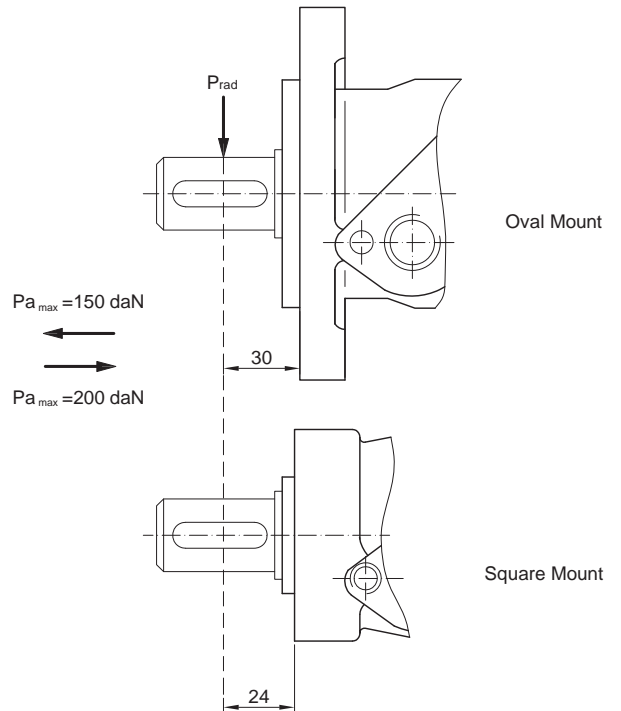

## HYDRAULIC MOTORS WITH SPEED SENSOR TYPE OP...RS

Meta Hydraulic is introducing hydraulic motor with a new generation of speed sensor. The electric output signal is a standard voltage signal that can be used for regulating the speed of a motor.  
The speed is measured by a sensor in accordance with the Hall principle. Signal processing and amplification are performed in the sensor housing. Connection is provided in the housing by a Plug connector M12 Series.

### OP...RS

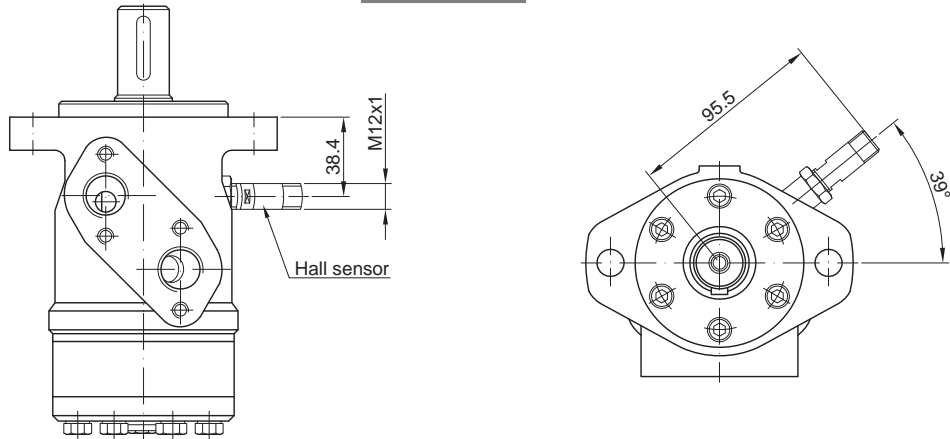

This performance is applicable for all motors of OP and OR series. The main technical features correspond to the standard motors series OP and OR. For detail technical and mounting data please refer to Meta catalogue.

## DIFFERENTIAL HALL SENSOR

### TECHNICAL DATA

Frequency range	3...20 000 Hz
Output	PNP
Power supply	10...36 VDC
Current input	20 mA (@24 VDC)
Current load	500 mA (@24 VDC;24°C)
Ambient Temperature	minus 40... plus 125°C
Protection	IP 67
Plug connector	M12-Series
Mounting principle	ISO 6149
Pulses per revolution	36

### OUTPUT SIGNAL

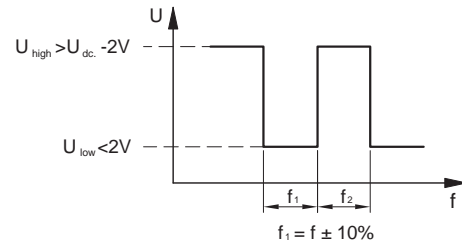

Load max.:  $I_{high}=I_{low}<50\text{mA}$   
No load current, max: 20 mA

### WIRING DIAGRAM

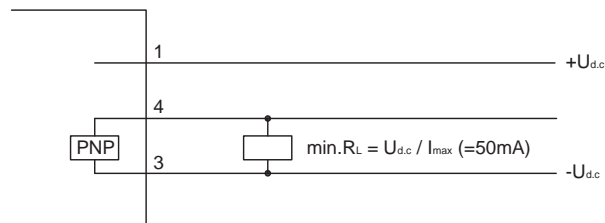

### STICK TYPE

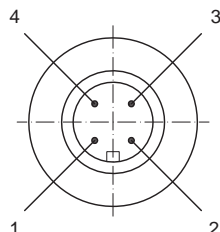

Terminal No.	Connection
1	Ud.c. (+supply)
2	No connection
3	Ud.c. (-supply)
4	Output signal

## ORDER CODE

	1	2	3	4	5	6	7	8	9	10	11	12
<b>OP</b>												

1	Case Drain
<b>omit</b>	with drain port
<b>U</b>	without drain port

2	Mounting Flange *
<b>omit</b>	Oval mount, two holes
<b>F</b>	Oval mount, four holes
<b>Q</b>	Square mount, four bolts
<b>W</b>	Wheel mount

3	Option (needle bearings) *
<b>omit</b>	none
<b>N</b>	with needle bearings

4	Port type
<b>omit</b>	Side ports
<b>E</b>	Rear ports

5	Displacement code
<b>25</b>	25,0 [cm <sup>3</sup> /rev]
<b>32</b>	32,0 [cm <sup>3</sup> /rev]
<b>40</b>	40,0 [cm <sup>3</sup> /rev]
<b>50</b>	49,5 [cm <sup>3</sup> /rev]
<b>80</b>	79,2 [cm <sup>3</sup> /rev]
<b>100</b>	99,0 [cm <sup>3</sup> /rev]
<b>125</b>	123,8 [cm <sup>3</sup> /rev]
<b>160</b>	158,4 [cm <sup>3</sup> /rev]
<b>200</b>	198,0 [cm <sup>3</sup> /rev]
<b>250</b>	247,5 [cm <sup>3</sup> /rev]
<b>315</b>	316,8 [cm <sup>3</sup> /rev]
<b>400</b>	396,0 [cm <sup>3</sup> /rev]
<b>500</b>	495,0 [cm <sup>3</sup> /rev]
<b>630</b>	623,6 [cm <sup>3</sup> /rev]

6	Shaft Extensions * (see page OP - 08)
<b>C</b>	ø25 straight, Parallel key A8x7x32 DIN6885
<b>VC</b>	ø25 straight, Parallel key A8x7x32 DIN6885 with corrosion resistant bushing
<b>CO</b>	ø1" straight, Parallel key 1/4"x1/4"x1 1/4" BS46
<b>VCO</b>	ø1" straight, Parallel key 1/4"x1/4"x1 1/4" BS46 with corrosion resistant bushing
<b>SH</b>	ø25,32 splined BS 2059 (SAE 6B)
<b>VSH</b>	ø25,32 splined BS 2059 (SAE 6B) with corrosion resistant bushing
<b>K</b>	ø28,56 tapered 1:10, Parallel key B5x5x14 DIN6885
<b>SA</b>	ø24,5 splined B 25x22 DIN 5482
<b>VSA</b>	ø24,5 splined B 25x22 DIN 5482 with corrosion resistant bushing
<b>CB</b>	ø32 straight, Parallel key A10x8x45 DIN6885
<b>KB</b>	ø35 tapered 1:10, Parallel key B6x6x20 DIN6885
<b>SB</b>	splined A 25x22 DIN 5482
<b>OB</b>	ø1 1/4" tapered 1:8, Parallel key 5/16"x5/16"x1 1/4" BS46
<b>HB</b>	ø1 1/4" splined 14T ANSI B92.1 - 1976

7	Ports
<b>omit</b>	BSPP (ISO 228)
<b>M</b>	Metric (ISO 262)

8	Special Features (see Specification data on page OP - 02 - OP - 03)
<b>omit</b>	none
<b>LL</b>	Low Leakage
<b>LSV</b>	Low Speed Valve
<b>FR</b>	Free Running

9	Rotation
<b>omit</b>	Standard Rotation
<b>R</b>	Reverse Rotation

10	Option (Paint)
<b>omit</b>	no paint
<b>P</b>	Painted
<b>PC</b>	Corrosion Protected Paint

11	Speed Monitoring
<b>omit</b>	none
<b>RS-P</b>	with speed sensor (PNP pull-down resistor)
<b>RS-N</b>	with speed sensor (NPN pull-up resistor)

The permissible output torque for shafts must be not exceeded!

\* The following combinations are not allowed - **Q, W, N** options with "...B" shafts.